

# SALES & ENGINEERING DATA

## PD20P-FXS-XXX and PE20P-FXS-XXX 2" NON-METALLIC DIAPHRAGM PUMP

RATIO SERIES:	<b>1:1</b>
FLUID P.S.I. RANGE:	<b>10 - 120</b>

RELEASED: 12-16-02  
REVISED: 9-14-06  
(REV. 05) S-1262

### DIMENSIONAL DATA

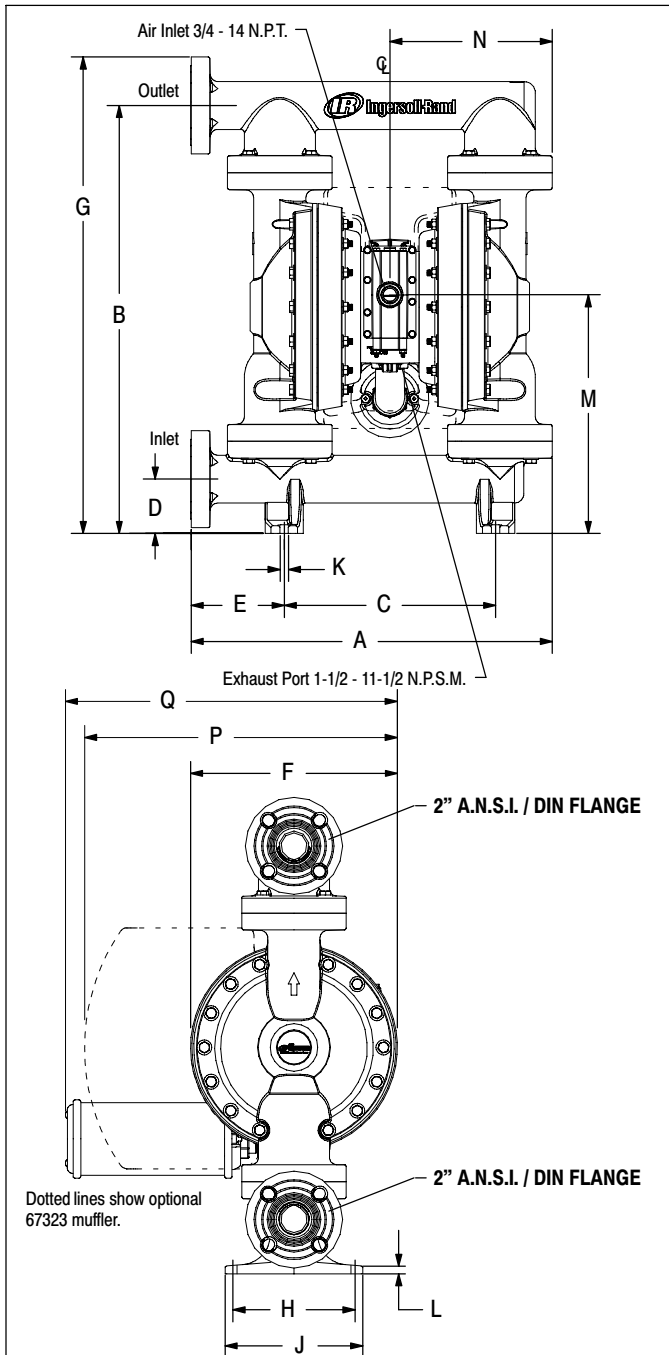

#### DIMENSIONS

A 24-3/16" (614.3 mm)	F 13-7/8" (352.0 mm)	L 1/2" (12.7 mm)
B 28-21/32" (728.0 mm)	G 31-29/32" (810.5 mm)	M 16" (405.9 mm)
C 14-5/32" (360.0 mm)	H 8-3/16" (207.8 mm)	N 10-7/8" (276.2 mm)
D 3-5/8" (92.2 mm)	J 9-7/32" (234.2 mm)	P 20-31/32" (532.2 mm)
E 6-1/4" (158.3 mm)	K 9/16" (14.3 mm)	Q 22-1/4" (564.9 mm)

NOTE: Dimensions are shown in inches and (mm) and are supplied for reference only.

### SPECIFICATIONS

#### CONSTRUCTION

Model Series	PD20P-FXS-XXX PE20P-FXS-XXX
Pump Type	Non-Metallic, Air Operated, Double Diaphragm
Ratio	1:1
Material Inlet / Outlet	2" A.N.S.I. / DIN Flange
Air Inlet (female)	3/4 - 14 N.P.T.
Air Exhaust (female)	1-1/2 - 11-1/2 N.P.S.M.
Weight	PX20P-FKS-XXX 110.9 lbs (50.3 kgs) PX20P-FPS-XXX 85.3 lbs (38.7 kgs)
Air Section Service Kit	637369
Fluid Section Service Kit	637373-XX

PX20P-FXS-X    
637373 -    
Diaphragm Material  
Ball Material

EXAMPLE: Model # PD20P-FKS-KAA  
Fluid Section Service Kit is 637373-AA

#### PERFORMANCE

Air Inlet Pressure Range	20 - 120 p.s.i. (1.4 - 8.3 bar)
Maximum Material Inlet Pressure	10 p.s.i. (0.69 bar)
Fluid Pressure Range	20 - 120 p.s.i. (1.4 - 8.3 bar)
Maximum Flow Rate (flooded inlet)	184 g.p.m. (696 l.p.m.)
Displacement / Cycle @ 100 p.s.i.	1.4 gal. (5.3 lit.)
Maximum Particle Size	1/4" dia. (6.4 mm)
Maximum Temperature Limits (diaphragm / ball / seal material)	
E.P.R. / EPDM	-60° to 280° F (-51° to 138° C)
Hytel	-20° to 150° F (-29° to 66° C)
Nitrile	10° to 180° F (-12° to 82° C)
Polypropylene	35° to 150° F (2° to 66° C)
Kynar PVDF	10° to 200° F (-12° to 93° C)
Santoprene	-40° to 225° F (-40° to 107° C)
Teflon PTFE	40° to 225° F (4° to 107° C)
Viton	-40° to 350° F (-40° to 170° C)
Noise Level @ 70 p.s.i. - 60 c.p.m.	85.0 db(A) <sup>①</sup>

① The pump sound pressure level has been updated to an Equivalent Continuous Sound Level (L<sub>Aeq</sub>) to meet the intent of ANSI S1. 13-1971, CAGI-PNEUROPS S5.1 using four microphone locations.

**PERFORMANCE CURVES**

**PX20P-FXS-XXX 2" NON-METALLIC DIAPHRAGM PUMP**

