

OPERATOR'S MANUAL

INCLUDING: SPECIFICATIONS, SERVICE KITS, GENERAL INFORMATION, PARTS, TROUBLESHOOTING
INCLUDE MANUAL: S-633 GENERAL INFORMATION (PN 97999-625)

612041-X

612042-X

RELEASED: 10-23-86
REVISED: 1-13-04
(REV. H)

**2" AIR MOTOR
1:1 RATIO
0 - 150 P.S.I. RANGE**

**2" DIFFERENTIAL
TRANSFER PUMP**



**READ THIS MANUAL CAREFULLY BEFORE INSTALLING,
OPERATING OR SERVICING THIS EQUIPMENT.**

It is the responsibility of the employer to place this information in the hands of the operator. Keep for future reference.

SERVICE KITS

- Use only genuine ARO® replacement parts to assure compatible pressure rating and longest service life.
- 637084 for air motor repair (see page 2).
- 637081 for lower pump end (Nitrile) repair (see page 3).
- 637083 for lower pump end (Teflon) repair (see page 3).

SPECIFICATIONS

Model Series	61204X-X
Type	Air Operated, transfer pump
Ratio	1:1
Air Motor Diameter	2" (5.08 cm)
Stroke	6" (15.24 cm)
Air Inlet (female)	1/4 - 18 N.P.T.F. - 1
Material Inlet	immersed
Material Outlet (female)	3/4 - 14 N.P.T.F. - 1
Pump Construction	Carbon Steel
Dimensional Data	See Chart
Weight	See Chart

PERFORMANCE

Air Inlet Pressure Range	0 - 150 p.s.i. (0 - 10.3 bar)
Fluid Pressure Range	0 - 150 p.s.i. (0 - 10.3 bar)
Maximum Rec'd Cycles / Minute ..	75
Displacement In³ Per Cycle	18.8
Volume / Cycle	10.4 oz. (307.7 ml)
Cycles Per Gallon	12.3
Maximum Working Flow Rate	9 g.p.m. (34.1 l.p.m.)
Maximum Flow Rate	18 g.p.m. (68.1 l.p.m.)
Noise Level @ 60 p.s.i., 40 c.p.m. ..	77.8 db(A)*

* The pump sound pressure level has been updated to an Equivalent Continuous Sound Level (L_{Aeq}) to meet the intent of ANSI S1. 13-1971, CAGI-PNEUROPS.1 using four microphone locations.

GENERAL DESCRIPTION

The Aro 2" differential 1:1 ratio transfer pumps are intended to be used primarily for oil transfer and delivery systems. It is best to use this pump with low - medium viscosity fluids. It uses carbon steel and other materials which make it compatible with most petroleum based lubrication products.

OPERATING AND SAFETY PRECAUTIONS

⚠ WARNING Read the General Information Manual for operating and safety precautions and important information.

INGERSOLL-RAND COMPANY
P.O. BOX 151 • ONE ARO CENTER • BRYAN, OHIO 43506-0151
☎ (419) 636-4242 • FAX (419) 633-1674 ©2004 CCN 99444598

PUMP DATA

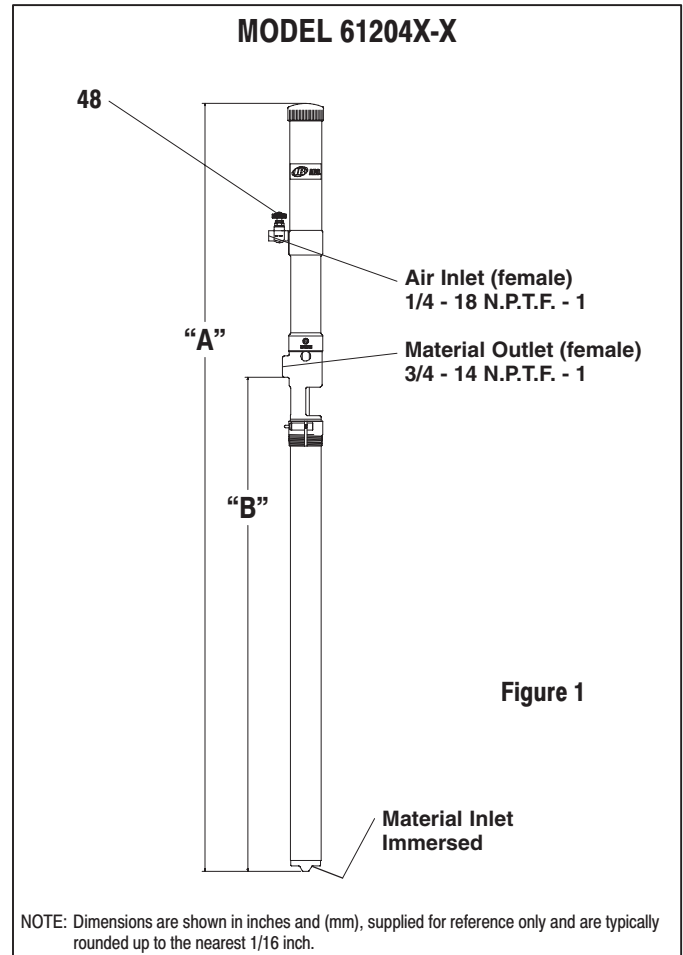

MODEL	"A" (mm)	"B" (mm)	WEIGHT (kg)
612041-X	54" (1371.6)	34-5/8" (879.5)	13 lb (5.9)
612042-X	64-1/4" (1631.9)	44-7/8" (1139.8)	14 lb (6.4)

IMPORTANT

This is one of two documents which support the pump. Replacement copies of these forms are available upon request.

- 612041-X MODEL OPERATOR'S MANUAL
- S-633 GENERAL INFORMATION LUBRICATION PISTON PUMPS



PARTS LIST / AIR MOTOR SECTION

Item	Description (size in inches)	Qty	Part No.	[Mtl]
1	Cap	(1)	76073-2	[A]
2	Washer	(1)	77290	[C]
✓ 3	"O" Ring (3/32" x 2-5/16" o.d.)	(1)	Y325-138	[B]
4	Spring	(1)	77208	[C]
5	Button	(1)	90638	[C]
6	Cylinder	(1)	76074-2	[A]
✓ 7	Spacer and Piston Assembly	(1)	61088	
8	Screw (#4 - 40 x 3/8")	(3)	Y222-54-C	[C]
9	Valve Plate	(1)	76090	[C]
10	Piston Assembly	(1)	60656	[B/C]
11	Valve Spacer	(1)	76856	[D]
✓ 12	Gasket	(1)	F21-53	[Co]
13	Plunger Tip	(1)	77794	[C]
✓ 14	"O" Ring (1/8" x 1-1/4" o.d.)	(1)	Y325-214	[B]
15	Plunger	(1)	76215	[C]
✓ 16	"O" Ring (3/32" x 2-1/16" o.d.)	(1)	Y325-134	[B]
17	Spring	(1)	76070	[C]
18	Pump Body	(1)	77807	[A]
✓ 19	"O" Ring (.275" x 1.837" o.d.)	(1)	77803	[B]
20	Ground Screw (#10 - 32 x 1/4")(page 3)	(1)	93005	[C]
21	Dowel Pin (3/16" dia. x 1-1/8")	(1)	Y148-29	[C]
✓	Parts in Repair Kit		637084	

MATERIAL CODE

[A] = Aluminum	[C] = Cast Iron	[SS] = Stainless Steel
[B] = Nitrile	[Co] = Copper	[T] = Teflon
[Br] = Brass	[D] = Acetal	[V] = Viton
[C] = Carbon Steel	[NY] = Nylon	

PUMP DISASSEMBLY

NOTE: All threads are right hand.

- Place the 2" differential pump in a vise. Rotate the pump so the material outlet is resting against the vise jaw. CAUTION: Do not clamp the pump too tightly.

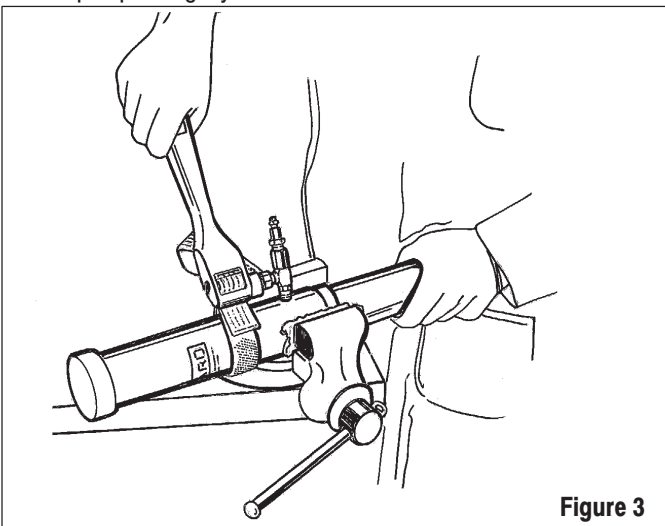

Figure 3

- Place a strap wrench around the (1) cap and remove the cap. If the (6) cylinder comes off with the (1) cap, place the cap in a vise and use a strap wrench around the (6) cylinder to unscrew it from the cap. NOTE: Do not squeeze or use a pipe wrench on (6) cylinder.

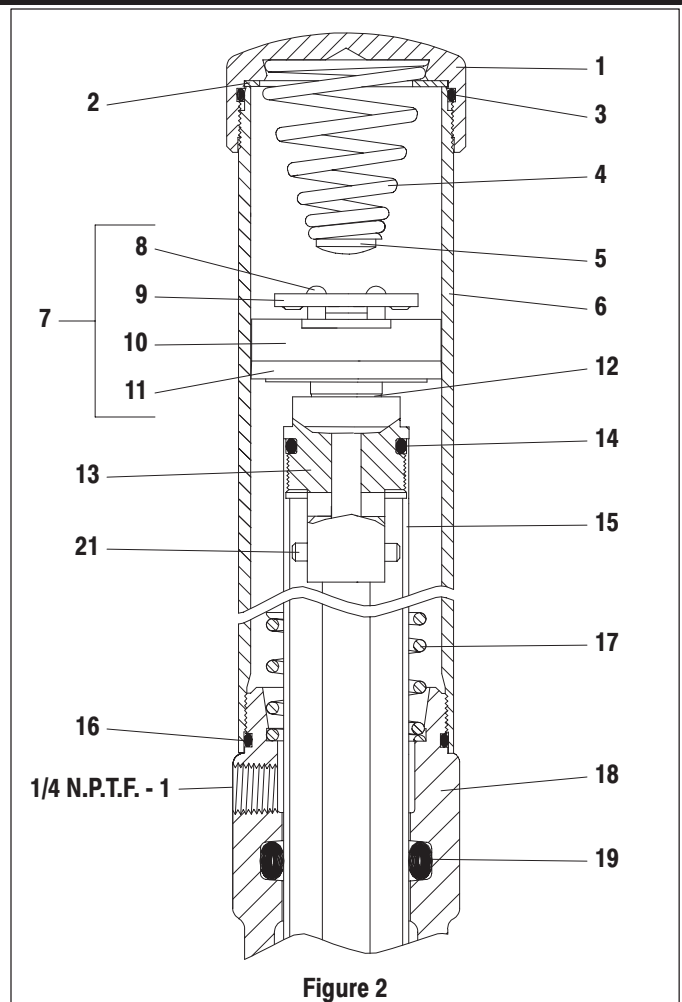

Figure 2

- Remove (3) "O" ring.
- Using a strap wrench, as shown in figure 3, unthread and remove the (6) cylinder from the (18) pump body.
- Remove (16) "O" ring from the (18) pump body.
- Unthread and remove (7) spacer and piston assembly from the (13) plunger tip.
- Remove (12) gasket from (13) plunger tip.

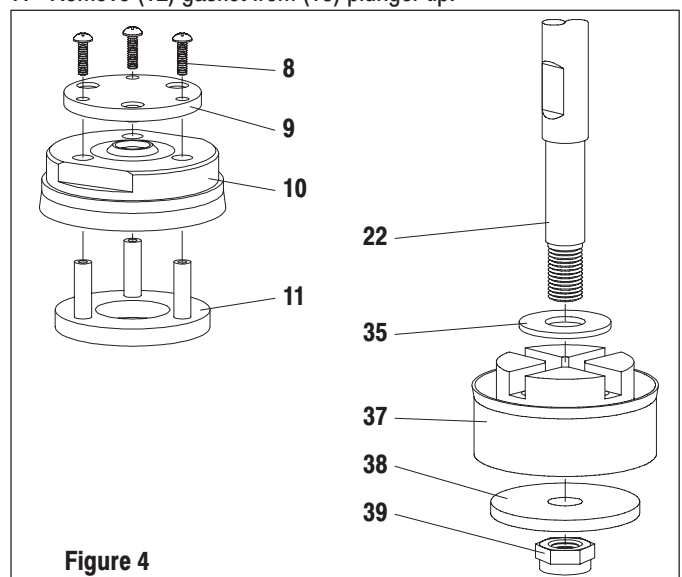

Figure 4

(continued on page 4)

PARTS LIST / LOWER PUMP SECTION

Item	Description (size in inches)	Qty	Part No.	[Mtl]
22	Piston Rod	(1)	77804	[C]
23	"O" Ring (1/16" x 5/8" o.d.)	(1)	Y325-14	[B]
24	Plug	(1)	79057	[NY]
<input type="checkbox"/> 25	"O" Ring (3/32" x 2-1/16" o.d.)			
	models 61204X-1	(1)	Y325-134	[B]
	models 612041-3	(1)	Y327-134	[V]
<input type="checkbox"/> 26	"O" Ring (3/32" x 1-7/16" o.d.)			
	models 61204X-1	(1)	Y325-124	[B]
	models 612041-3	(1)	Y327-124	[V]
27	Groove Pin (1/8" dia. x 3/4")	(1)	Y122-85	[C]
28	Collar	(1)	76900	[C]
29	Washer (models 612041-3 only)	(1)	77910	[C]
<input type="checkbox"/> 30	Packing (models 61204X-1 only)	(2)	75649	[B]
<input type="checkbox"/> 31	"O" Ring (1/16" x 1/2" o.d.)			
	models 61204X-1	(1)	Y325-12	[B]
	models 612041-3	(1)	Y327-12	[V]
32	Retaining Ring	(1)	77801	[C]
<input type="checkbox"/> 33	Piston models 61204X-1	(1)	75648	[D]
	models 612041-3	(1)	77827	[T]
34	Suction Tube models 612041-X	(1)	77798	[C]
	models 612042-1	(1)	77814	[C]
35	Washer	(1)	77797	[C]
36	Tube	(1)	77806	[C]
<input type="checkbox"/> 37	Cup models 61204X-1	(1)	77796	[B]
	models 612041-3	(1)	77826	[T]
38	Washer	(1)	77800	[C]
39	Nut (3/8" - 24)	(1)	Y115-14	[SS]
40	Stem	(1)	76093	[C]
41	Plate	(1)	F58-3	[C]
42	Valve Body	(1)	F259-1	[C]
43	Foot Valve Asm (includes items 40 - 42)	(1)	60657	
44	Bung Adapter (includes item 45)	(1)	60870	[C]
45	Screw (1/4" - 20 x 1-1/2")	(1)	Y197-158-C	[C]
48	Needle Valve (see figure 1)	(1)	92818	[Br]

- Parts included in 637081 service kit (models 61204X-1).
 Parts included in 637083 service kit (models 612041-3).

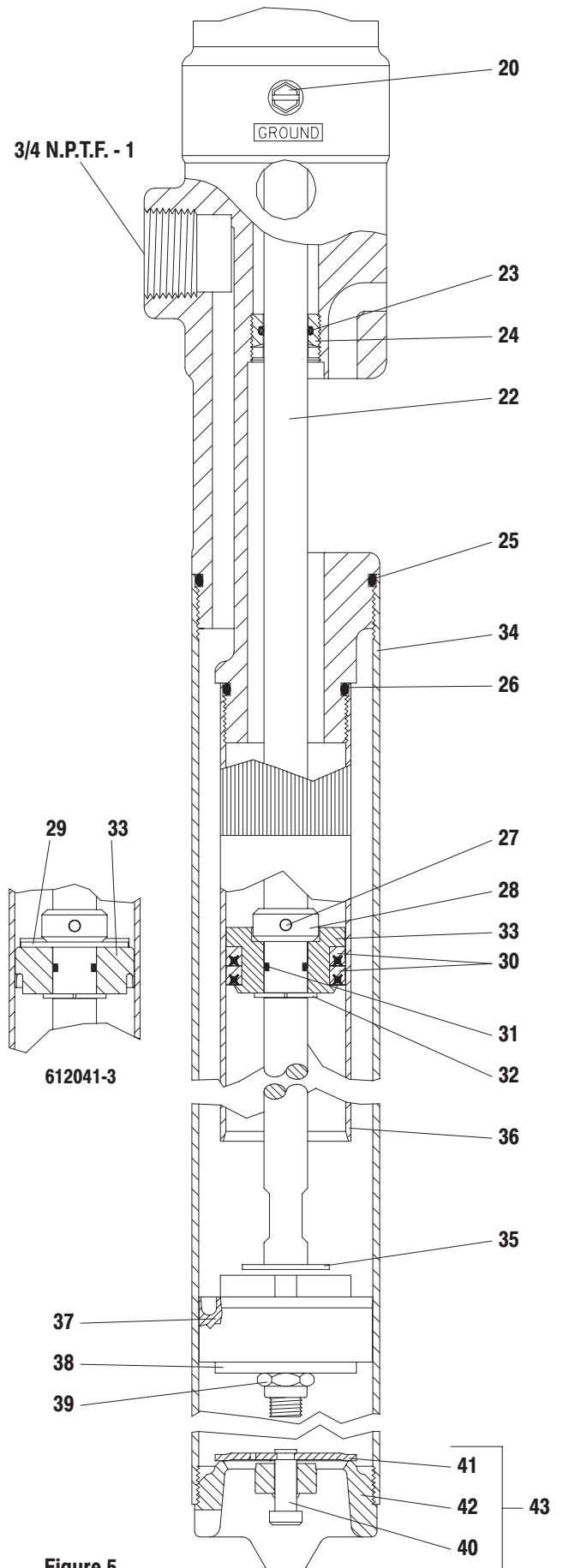

Figure 5

PUMP DISASSEMBLY (continued)

NOTE: Perform steps 8 thru 10 only if (7) spacer and piston assembly needs servicing.

8. Remove the three (8) screws from the (11) valve spacer (see figure 4).
9. Remove the (9) valve plate.
10. Remove the (11) valve spacer from the (10) piston assembly.
11. Unthread (13) plunger tip from the (15) plunger by using a wrench on the flats of the (13) plunger tip and a strap wrench on the (15) plunger. CAUTION: Place the strap wrench on the very upper most part of the (15) plunger.
12. Remove (14) "O" ring.
13. Remove (21) dowel pin.
14. Remove (13) plunger tip.
15. Remove (15) plunger.
16. Remove (17) spring from the (18) pump body.
17. Remove (19) "O" ring from the (18) pump body.
18. Using a pipe wrench, unthread and remove the (34) suction tube from the (18) pump body. CAUTION: Place the pipe wrench on the very upper most or very lower most part of the (34) suction tube. Do not damage or dent this tube.
19. Remove (25) "O" ring from the (18) pump body.
20. Grasp the (22) piston rod and remove by pulling straight out.
21. Using a strap wrench on (36) tube, unthread and remove from (18) pump body. CAUTION: Do not damage or dent this tube.
22. Remove (26) "O" ring from (18) pump body.
23. Remove (24) plug and (23) "O" ring.
24. Clamp the (43) intake valve assembly in a vise. Using a strap wrench on (34) suction tube, unthread and remove from valve assembly. CAUTION: Do not damage or dent this tube.
25. Using a wrench on flats of (22) piston rod, unthread and remove (39) nut (see figure 4).
26. Remove (38) washer, (37) cup and (35) washer from (22) piston rod.
27. Remove (32) retaining ring from the (22) piston rod, using retaining ring pliers.
28. Remove (33) piston from (22) piston rod.
29. Remove two (30) packings (where applicable).
30. Remove (31) "O" ring from (22) piston rod.
31. NOTE: Do not remove (27) groove pin and (28) collar from (22) piston rod unless damage is evident. Remove (27) groove pin, releasing (28) collar.

PUMP REASSEMBLY

1. Insert the (11) valve spacer thru the bottom of the (10) piston assembly (see figure 4).

2. Place the (9) valve plate on top of the (10) piston assembly, aligning the three holes with the posts of (11) valve spacer.
3. Fasten the (9) valve plate down using the three (8) screws. Lay this assembly aside for the moment.
4. Place the (28) collar on the (22) piston rod and secure with (27) groove pin.
5. Assemble (29) washer next to (28) collar on (22) piston rod.
6. Grease and assemble (31) "O" ring to (22) piston rod.
7. Assemble two (30) packings to (33) piston (where applicable).
8. Assemble (33) piston to (22) piston rod, securing with (32) retaining ring.
9. Assemble (35) washer, (37) cup (lips up) and (38) washer onto (22) piston rod, securing with (39) nut (see figure 4).
10. Grease and assemble (23) "O" ring into (24) plug and screw (24) plug into (18) pump body.
11. Place the (18) pump body in a vise and rotate it so the material outlet is resting against the vise jaw. CAUTION: Do not clamp the pump body too tightly.
12. Grease and assemble (26) "O" ring to (18) pump body.
13. Thread (36) tube onto (18) pump body and tighten, using a strap wrench.
14. Assemble the (22) piston rod up thru the (18) pump body.
15. Grease and assemble (25) "O" ring to (18) pump body.
16. Thread the (34) suction tube to the (18) pump body and tighten, using a strap wrench.
17. Thread the (43) intake valve assembly to the (34) suction tube and tighten.
18. Grease and assemble (19) "O" ring into (18) pump body.
19. Place (17) spring into (18) pump body.
20. Assemble (15) plunger over (22) piston rod.
21. Assemble (13) plunger tip to (22) piston rod and insert (21) dowel pin to secure plunger tip.
22. Grease and assemble (14) "O" ring to (13) plunger tip.
23. Pull (15) plunger up and thread (13) plunger tip to plunger and tighten by using a wrench on flats of (13) plunger tip and a strap wrench on (15) plunger.
24. Place the (12) gasket over the end of (13) plunger tip.
25. Thread the (7) spacer and piston assembly onto the (13) plunger tip and tighten.
26. Grease and assemble (16) "O" ring to (18) pump body.
27. Thoroughly grease the inside of the (6) cylinder and assemble over the (7) spacer and piston assembly, threading onto the (18) pump body.
28. Assemble (2) washer, (3) "O" ring, (4) spring and (5) button into (1) cap and assemble cap to (6) cylinder, tightening using a strap wrench.

TROUBLE SHOOTING

Pump continually cycles.

- Check for empty material supply. Disconnect the air (from the pump) replenish material supply.
- Check for worn or damaged (30) packing or (33) piston.

Material on one stroke only (fast downstroke).

- The intake valve assembly may not be checking or sealing properly. Remove the intake valve assembly and inspect. If the valve assembly is damaged, replace with new parts. If the valve assembly is not damaged, thoroughly clean and reassemble to the pump (see pump instructions).

Material on one stroke only (fast upstroke).

- Check for worn or damaged (37) cup. Replace cup (see pump instructions and figure 4).

Material leakage out the top of the pump body.

- Check for worn or damaged (30) packing or (33) piston.

Air leakage out of the exhaust holes. (See Air Motor Instructions)

- Check to see if the (9) valve plate is loose or has become disassembled from the (11) valve spacer.
- Check for worn or damaged (10) piston assembly.
- Check for worn or warped (9) valve plate.
- Worn or damaged (14) "O" ring. Replace (14) "O" ring.

