

OPERATOR'S MANUAL

651747-X-B

INCLUDING: OPERATION, INSTALLATION & MAINTENANCE

RELEASED: 6-28-92
REVISED: 7-16-01
(REV. G)

STAINLESS STEEL FLUID HEATER



READ THIS MANUAL CAREFULLY BEFORE INSTALLING, OPERATING OR SERVICING THIS EQUIPMENT.

It is the responsibility of the employer to place this information in the hands of the operator. Keep for future reference.

FLUID HEATER DATA

Models	651747-X-B
Wetted Parts Material	Stainless Steel
Volts AC	651747-1-B 120 651747-2-B 230 / 240 651747-3-B 415 / 440
Amperes	651747-1-B 16.6 651747-2-B 8.3 651747-3-B 4.5
Watts	2000
Accuracy	±3-1/2° F (1.9° C)
Temperature Rise Above Ambient	100° F (38° C)
Recovery Rate per Hour	15 gallons (56.8 liters)
Maximum Working Pressure	5000 p.s.i. (35 MPa)
Maximum Temperature Range	60 - 250° F (16 - 121° C)
Surface Temperature Code	T3 (392° F / 200° C)
Fluid Passage Diameter	0.370" (9.4 mm)
Fluid Passage Length	91.7" (232.9 cm)
Fluid Passage Volume	9.86 in. ³ (0.162 lit.)
Inlet / Outlet Port Size (female)	1/2 - 14 N.P.T.F. - 1
Weight	18 lbs (8.2 kg)

GENERAL DESCRIPTION

The Aro stainless steel fluid heater models are wired for 120, 230 / 240 and 415 / 440 volt AC applications. The heating element is a 2000 watt cartridge type and is thermostatically controlled. The wiring, heating element and thermostat are protected by a preset heat limiter.

The thermostat is adjustable up to 250° F (121° C). The heater is off when the thermostat knob is turned counterclockwise as far as possible. The heater will not switch on until the knob is rotated to at least ambient room temperature.

Fluid heaters have been tested in a water solution. Some of this fluid may be left within the heater, therefore flush out this fluid with a solvent compatible with the material to be pumped.

- This unit utilizes an explosion-proof electrical section and internally spiraling material section. The material enters the base under line pressure from the pump and is heated and delivered thru to the material outlet at the top.
- This unit is CSA certified for Class I, Division 1, Group D, Hazardous Locations, Temperature Code (identification number) T3.
- Two or more paint heaters may be coupled together by plumbing the material outlet of the first heater to the material inlet of the next, etc. However, the distance of piping run between the units should be limited to no more than three feet (see figure 4, page 4).

TYPICAL INSTALLATION

The heater inlet and outlet should be plumbed (up flow) as shown (see figure 4, page 4), to minimize chances of trapped air inside the heater. If the inlet and outlet are reversed (down flow), the temperature rise will be different.

DIMENSIONAL DATA

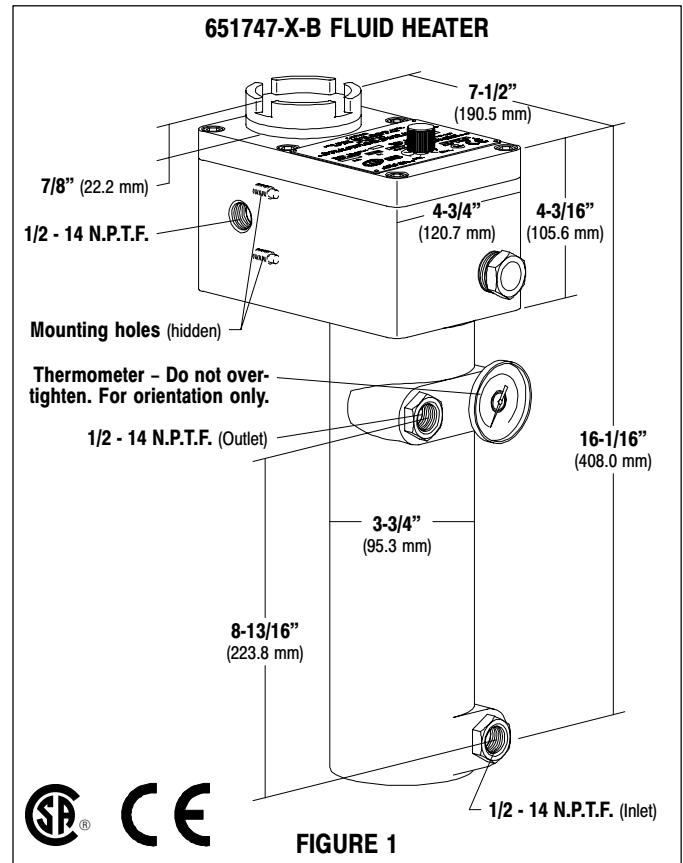

FIGURE 1

OPERATING PRECAUTIONS

- Heed all warnings.
 - ⚠ **WARNING** Do not exceed 5000 p.s.i. (35 MPa) maximum.
 - ⚠ **WARNING** HIGH PRESSURE DEVICE. Improper usage of this equipment could result in serious injury. The possibility of injection into the flesh is a potential hazard. Never allow any part of the human body to come in front of, or in direct contact with, the material outlet. An injection injury can be serious. If injection should occur, contact a qualified physician for immediate treatment.
 - ⚠ **CAUTION** Electrical supply power to the heater must be off during flushing operation.
 - ⚠ **CAUTION** Use only genuine Aro replacement parts to assure compatible pressure rating and longest service life.



POWER SUPPLY AND INSTALLATION

NOTE: The power supply cable is not furnished with the unit and must be supplied by the customer.

Do not use neutral as earth ground. A single phase power / earth ground is required. If this is not available, use a transformer to obtain single phase power.

Provisions should be made for a quick disconnect or shut-off of all electrical power to this unit.

All wiring must comply with all local and / or national electrical codes.

- Electrical codes that apply must be strictly adhered to. Failure to do so may lead to shock hazard or serious injury.
- Some local electrical codes may require the installation of rigid conduit.
- The installer of this system assumes full responsibility for compliance with these codes.
- Aro is not responsible for accidents resulting from improper installation of components or hardware.
- No electrical power should be in the system at the time the cover is removed.

AIR AND LUBE REQUIREMENTS

Commonly used solvents and their lowest boiling points as pertains to the Aro free flow system:

Hydrocarbons (Petroleum Naphthas)	Boiling Point ° F (° C) ☆
VM & P	244 (118)
Mineral Spirits	314 (157)
Odorless Mineral Spirits	353 (178)
Aromatics (Terpenes)	
Benzene	172 (78)
Toluene	230 (110)
Xylene	281 (138)
Gum Turpentine	311 (155)
Dipentene	347 (175)
Alcohols	
Methanol	147 (64)
Isobutyl Alcohol	223 (106)
Nybutyl Alcohol	241 (116)
Keytones	
MEK	174 (79)
Acetone	122 (50)
Diacetone	284 (140)

☆ International Critical Tables (ref.)

OPERATING INSTRUCTIONS

START-UP PROCEDURE

1. Fill the system with fluid.
2. Circulate the fluid thru the system.

⚠ CAUTION Power should never be on when there is only solvent in the system. Solvents can expand if there is no circulation, causing excessive and hazardous pressure in the system.

3. Turn the power on.
4. Set the thermostat just below the boiling point of the lowest boiling solvent in the coating material (see table above).
5. Allow fluid to circulate thru the heater for 5 - 10 minutes.
6. Readjust the thermostat as necessary.

To adjust the temperature, turn the knob:

- a. Clockwise – higher temperature
- b. Counterclockwise – lower temperature

SHUTTING THE SYSTEM OFF

1. Allow the fluid to circulate for 5 - 10 minutes after shutting the heater off, to cool the system.
2. Always leave the solvent or fluid in the heater.

MAINTENANCE

NOTE: The (22) fluid track is a cast assembly and cannot be disassembled for cleaning. **Do not allow material to solidify inside the heater.** Flush the paint heater with the proper solvent immediately following each use.

⚠ CAUTION Shut the electrical supply off and relieve all pressure from the system before servicing any part of the fluid heater system.

CLEANING

1. When cleaning the fluid heater, use only solvents compatible with the material being pumped.
2. The fluid heater should be flushed with solvent when changing medias, or when it is not being used for a period of time.

NOTE: For other maintenance problems, see "Trouble Shooting", page 4.

DISASSEMBLY

NOTE: The following procedure is for the repair of the (24) heater cartridge assembly, (29) thermostat or the (23) cutoff assembly.

1. Relieve all fluid pressure in the system.
2. Rotate the (17) adjusting knob counterclockwise to the "off" position.
3. Disconnect the power supply to the fluid heater assembly.
4. Disconnect the fluid lines.
5. Remove the six (2) cap screws.
6. Remove the (20) cover.
7. Remove the two (12) machine screws and (11) lockwashers from the (21) housing, which retain the thermostat assembly.
8. Remove (as one unit) the (10) terminal block, (29) thermostat and (13) mounting plate by carefully lifting it out and removing the power lead wires (1 and 3) from the first two positions on the (10) terminal block (refer to figure 3).
9. Remove the (24) heater cartridge assembly leads from the (10) terminal block third and fourth positions.
10. Carefully finish removing the assembly by pulling the thermostat capillary tube out of the (22) fluid track body.

NOTE: Special care must be taken not to sharply bend or kink the capillary tube which will ruin the thermostat. Do not use pliers or other tools which may also damage the tube.

11. Remove the (28) indicator lamp leads from the (10) terminal block third and fourth positions.
12. Unscrew the (15) site plug to remove the (28) indicator lamp from the assembly.
13. Remove the (23) cutoff assembly leads from the (10) terminal block second and fourth positions. Carefully remove the (23) cutoff assembly from the (22) fluid track.

HEATER CARTRIDGE REMOVAL

1. Pull the (24) heater cartridge assembly from the (22) fluid track. NOTE: If the (24) heater cartridge assembly does not easily come out, do the following:
 - a. Remove the (25) pipe plug from the bottom of the (22) fluid track.
 - b. Carefully drive the (24) heater cartridge assembly out thru the top of the heater (toward the cover).

REASSEMBLY

1. Reassembly is done in the reverse order.

NOTE: Care must be taken to keep the (29) capillary tube away from the (23) cutoff assembly.

NOTE: When reinstalling the (20) cover, be certain the (17) adjusting knob is turned out. If the (18) screw is threaded in too far, it will inhibit the cover from properly sealing flat against the housing.

2. Rotate the adjusting knob clockwise out as far as it will go and turn it back in carefully to align the slots with the thermostat.
3. Apply Watt Lube to (24) heater cartridge assembly.
4. Apply Dow Corning 340 Silicone Heat Sink compound to the (29) thermostat probe and (23) cutoff assembly. This material increases the overall efficiency of the devices.

PARTS LIST / 651747-X-B

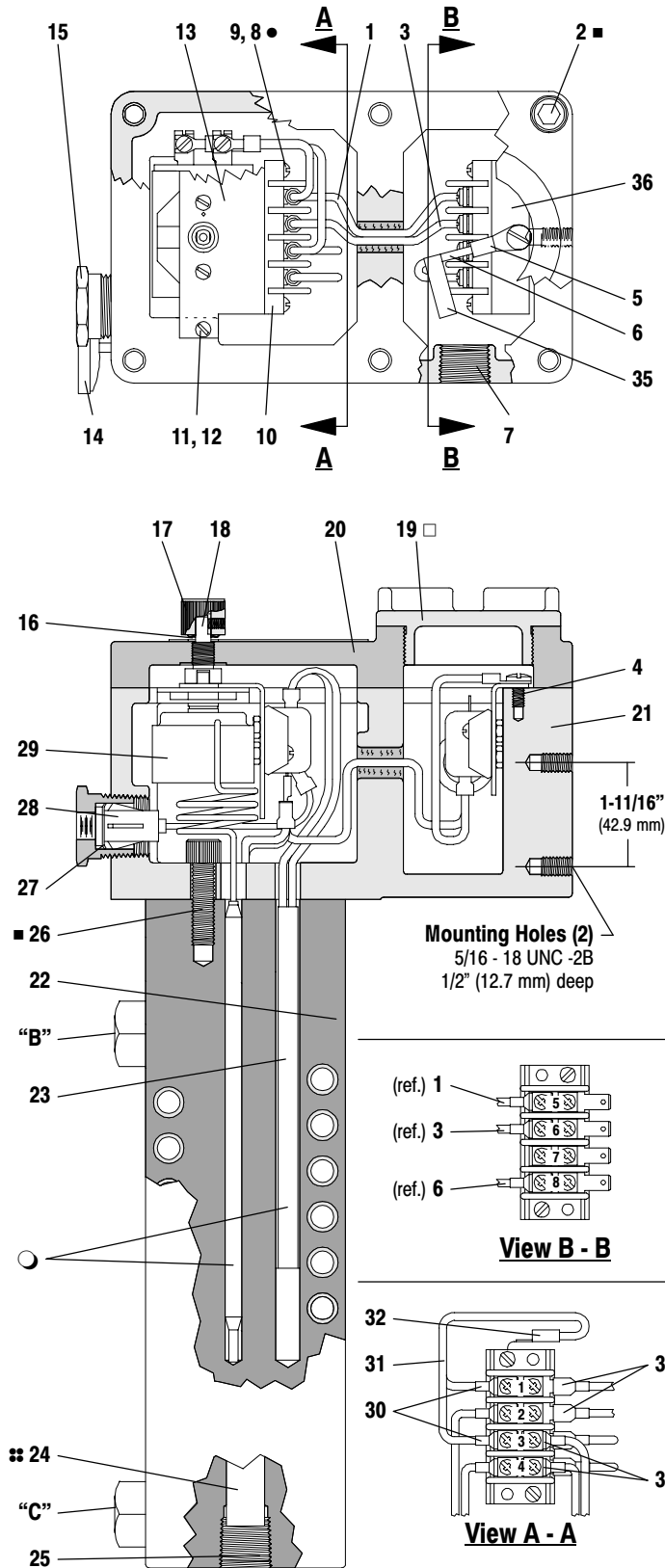

FIGURE 2

“B” Outlet (1/2 - 14 N.P.T.F. - 1)
 “C” Inlet (1/2 - 14 N.P.T.F. - 1)

- (2 and 26) Torque to 10 - 12 ft lbs (13.6 - 16.3 Nm).
- (8) Apply Loctite 242 to threads.
- (19) Apply Nickel anti-seize to threads.
- ⌘ (24) Apply Watt Lube.
- Apply Dow Corning 340 Silicone Heat Sink Compound.

ITEM	DESCRIPTION (Size in inches)	QTY	PART NO.
* 1	14 Gauge Wire (12" long, black)	(1)	78140-XXX-X
2	Cap Screw (3/8" - 16 x 7/8")	(6)	Y99-678
* 3	14 Gauge Wire (12" long, red)	(1)	78141-XXX-X
4	Machine Screw (#10 - 24 x 1/4")	(1)	Y76-103-C
5	Ring Terminal	(1)	78143
* 6	14 Gauge Wire (7" long, green)	(1)	78142-XXX-X
7	Pipe Plug (1/2 - 14 P.T.F.)	(1)	Y227-5-L
8	Machine Screw (#6 - 32 x 5/8")	(4)	Y8-468-C
9	Nut (#6 - 32)	(4)	Y22-6-C
10	Terminal Block	(2)	92932
11	Lockwasher (#6)	(4)	Y1-6
12	Machine Screw (#6 - 32 x 1/4")	(4)	Y8-463-C
13	Mounting Plate	(1)	93583-1
14	Thermometer (0° - 250° F)	(1)	91696
15	Site Ring	(1)	93588-1
16	Retaining Ring	(1)	29664
17	Adjusting Knob	(1)	93586-1
18	Screw	(1)	93585-1
19	Cap	(1)	93584-1
20	Cover	(1)	93587-1
21	Housing	(1)	93590-1
22	Fluid Track	(1)	92974
23	Cutoff Assembly	(1)	66834-1
24	Heater Cartridge Assembly (+10% / -5%)		
	651747-1-B (120 volt AC, 6.84 Ohms)	(1)	66751-1
	651747-2-B (230 / 240 volt AC, 27.36 Ohms)	(1)	66751-2
	651747-3-B (415 / 440 volt AC, 91.96 Ohms)	(1)	66751-3
25	Pipe Plug (1/2 - 14 N.P.T.)	(1)	Y17-53
26	Cap Screw (3/8" - 16 x 1-1/4")	(3)	Y99-63
27	Retaining Ring	(1)	93589-1
28	Indicator Lamp models 651747-1-B (120 volt AC)	(1)	93591-1
	models 651747-2-B (220 volt AC)	(1)	93591-3
	models 651747-3-B (440 volt AC)	(1)	93591-5
29	Thermostat (60° - 250° F) (20 amp. / 480 volt AC)	(1)	92972
30	Terminal	(5)	78035
* 31	14 Gauge Wire (6" long, black)	(2)	78140-XXX-X
32	Terminal	(2)	78143
33	Terminal	(2)	78034-1
34	Terminal	(2)	78031
35	Label	(1)	91081
36	Mounting Plate	(1)	95634

* Available in bulk rolls only.

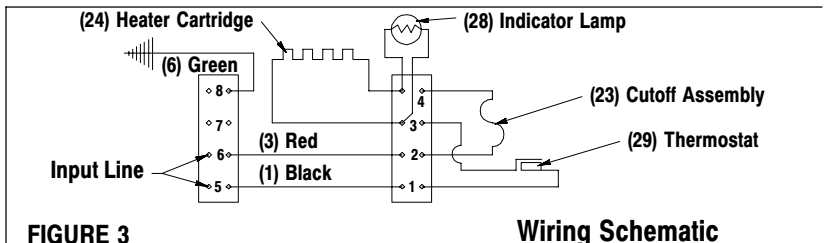

FIGURE 3

Wiring Schematic

TROUBLE SHOOTING

Fluid heater will not produce heat.

- No current to the heater unit.
Check the main power switch.
Check the power supply fuse, etc.
- Damaged thermostat.
Replace the thermostat.
- The heat limiter is burned out.
Replace the heat limiter.
- The heat element is burned out.
Replace the heater cartridge element.

Correct the wiring.

- Material build-up inside the heater.
Clean the fluid heater and material lines.

Inadequate material flow.

- Material build-up inside the heater.
Clean the fluid heater and material lines.

The temperature of the material is too low.

- The voltage to the heater is too low.
Correct the wiring.
- The thermostat is damaged.
Replace the thermostat.
- The thermostat setting is wrong.
Adjust the thermostat.
- Material build-up inside the heater.
Clean the fluid heater and material lines.
- The material flow is too fast.
Reduce the material flow.

The temperature of the material is too high.

- The thermostat is damaged.
Replace the thermostat.
- Wrong setting on the thermostat.
Reset the thermostat.

The heater takes too long to heat the material.

- The voltage is too low.

TYPICAL INSTALLATION

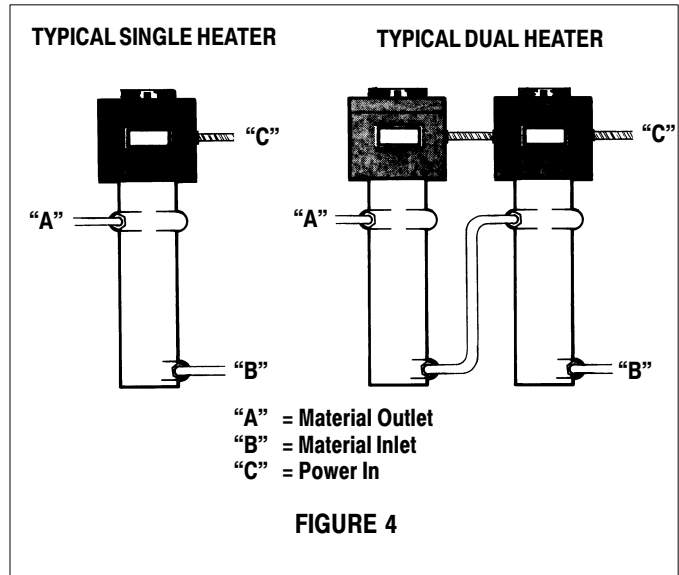

ACCESSORIES

