

POMPE VERTICALI

VERTICAL PUMPS



ewv 40



ESPLOSO
EXPLODED VIEW

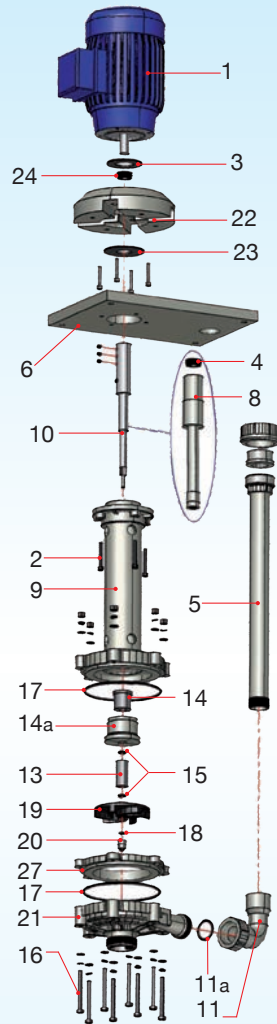

Descrizione particolari

1 Motore	14a Sede bussola stat.
2 Viti	15 O-Ring bussola
3 Deflettore	16 Viti corp. pompa
4 Anello tenuta	17 O-Ring corpo p.
5 Mandata	18 O-Ring ogiva
6 Piastra	19 Girante
8 Rivest. albero	20 Ogiva
9 Colonna	21 Corpo pompa
10 Albero	22 Lanterna
11 Gomito	23 Deflettore
11a O-Ring gomito	24 Anello tenuta
13 Bussola rotante	25 Ghiera bussola
14 Bussola statica	26 O-Ring ghiera

Part. description

1 Motor	14a Static bushing hous.
2 Screw	15 Bush O-Ring
3 Baffle	16 Pump housing bolts
4 Seal ring	17 Pump housing O-Ring
5 Discharge pipe	18 Ogive O-Ring
6 Support flange	19 Impeller
8 Shaft sleeve	20 Ogive
9 Pump column	21 Pump housing
10 Shaft	22 Vapour seal housing
11 Elbow	23 Baffle
11a Elbow O-Ring	24 Seal ring
13 Rotating bush	25 Nut bushing
14 Stating bushing	26 Nut O-ring

DATI TECNICI

SPECIFICATION

Portata max l/m	Prevalenza max m	Motore KW	IN/OUT D mm	T max esercizio °C	Peso Kg
Maximum capacity l/m	Total head	Motor KW	IN/OUT D mm	T max exercise °C	Weight * Kg
665	31	4	63 x 50	PP = 70°C	PP = 33 ÷ 43 *
665	31	4		PVDF = 95°C	

* Può variare in conformità al motore utilizzato ed alla profondità della pompa.

* It changes according with motor supplier and pump depth.



POMPE VERTICALI

VERTICAL PUMPS

ewv 40

DIMENSIONI
DIMENSION

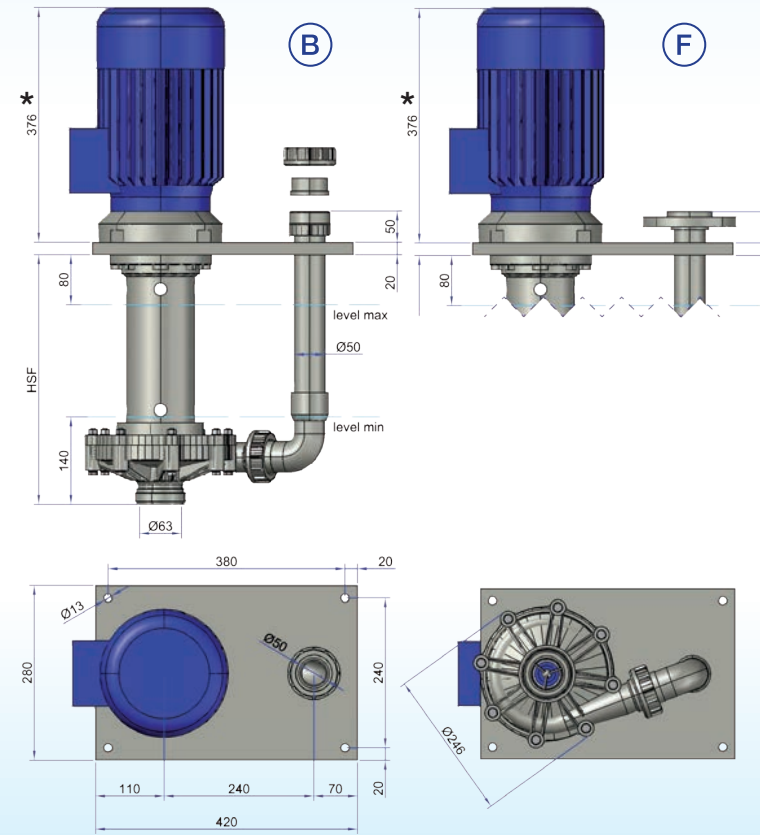

* Può variare in conformità al motore utilizzato

* It changes according with motor supplier

CURVE
PERFORMANCE

50 Hz

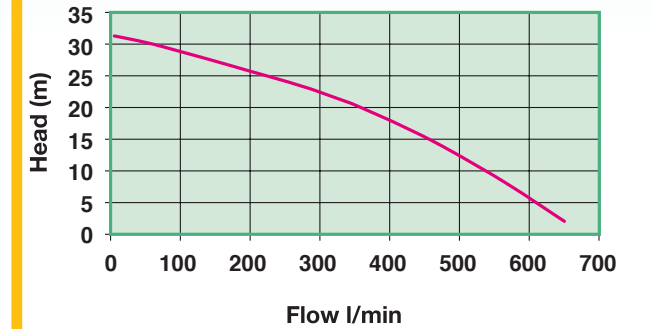

60 Hz

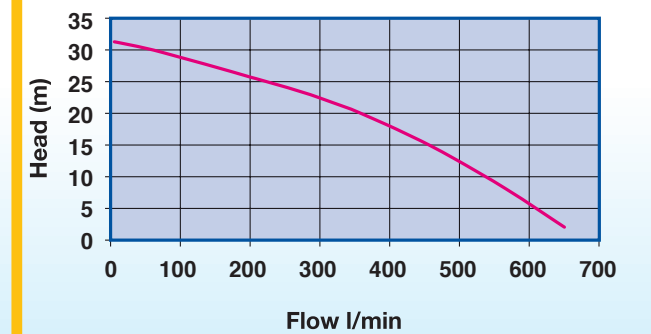

Riferimenti curve: acqua a temperatura ambiente
Curve references: water at room temperature

IDENTIFICAZIONE POMPA

PUMP IDENTIFICATION

Modello Model	Corpo pompa Pump body	Albero Shaft	Coppia di bussole statica/rotante Bushing couple static/rotating	HSF mm DEPTH mm	Attacchi Connections	Motore Motor	Optional Option
EVV40	P=PP	X= INOX AISI 316	1 = PTFE/PTFE 2 = PTFE/GRAFITE PTFE/CARBON 3 = PTFE/SIC	04 = 400 05 = 500 06 = 600 07 = 700 08 = 800 09 = 900 10 = 1.000 11 = 1.100 12 = 1.200 13 = 1.300 14 = 1.400 15 = 1.500 16 = 1.600 17 = 1.700 18 = 1.800 19 = 1.900 20 = 2.000	B= Bocchettoni Socket union F= Flangiati Flanged P= Portagomma Hosebarb	A= 50HZ B= 60 HZ	S= Succhieruola Strainer L= Lanterna Fume seal B= Bussola intermedia Additional bushing couple
	F=PVDF	T= TITANIO TITANIUM H= HASTELLOY	4 = GRAFITE/SIC CARBON/SIC 5 = GRAFITE/GRAFITE CARBON/CARBON 9 = SIC/SIC SIC/SIC				
EVV40	P	X	3	06	B	A	L